

● Features:

1. Input Voltage: 12VDC.
2. Input power: 3W.
3. Chip material: AlGaInP.
4. Emitted color: Red.
5. High lumen output.
6. High flux density.
7. Low power consumption.
8. Efficient heat transfer.
9. With heat sink.

● Applications:

1. Light engine.
2. Automotive lighting.
3. Decorating and entertainment lighting.
4. Architectural lighting.

● Package dimensions :

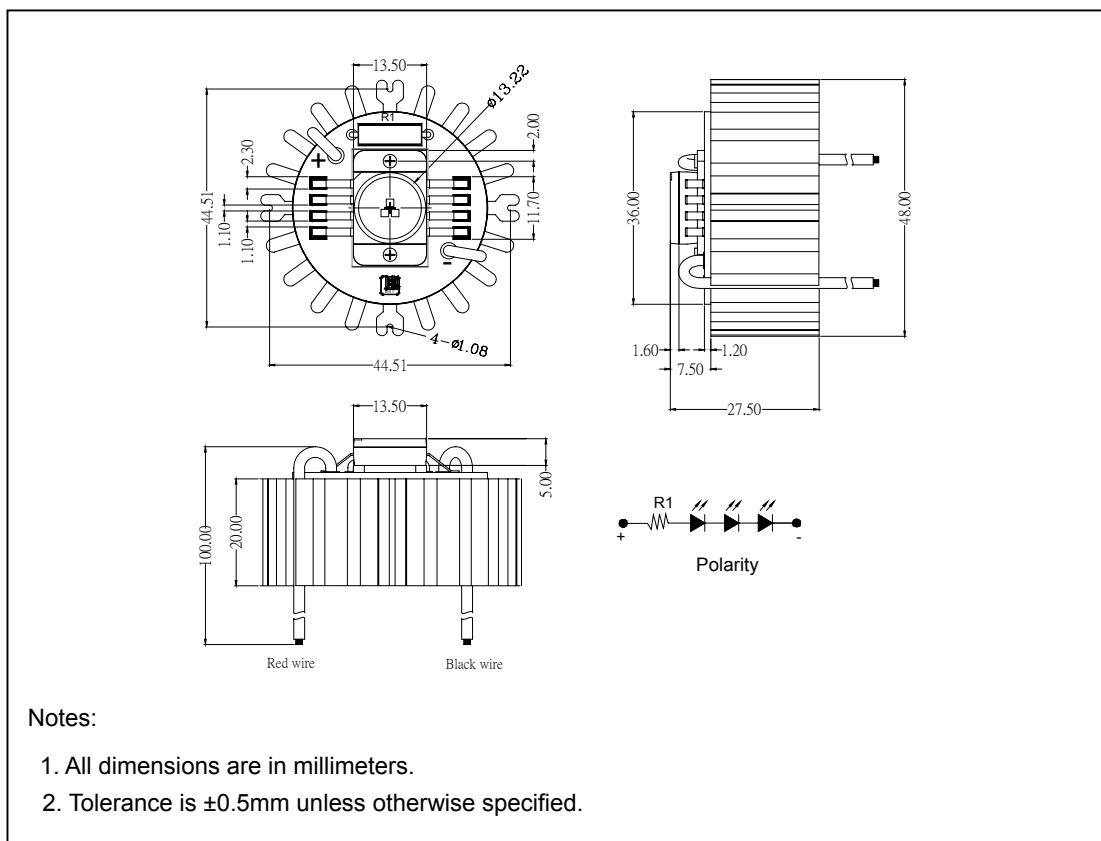

● **Absolute maximum ratings(Ta=25°C)**

Parameter	Symbol	Rating	Unit
Power Dissipation	P _D	3.0	W
DC Forward Current* ¹	I _F	350	mA
Peak Pulsed Forward Current* ²	I _{FP}	1.0	A
LED Junction Temperature	T _J	130	
Operating Temperature	Topr	-30~100	
Storage Temperature	Tstg	-40~120	
Reverse Voltage	V _R	15	V
Soldering Temperature (T=5 sec)	Tsol	300 ± 5	

*¹Proper current derating must be followed to keep LED junction temperature (T_J) below the maximum.

*²Condition for I_{FP} is pulsed with 1/10 duty and 0.1msec width.

● **Electrical & Optical Characteristics LED (Ta=25°C)**

Parameter	Symbol	Condition	Min.	Typ.	Max.	Unit
Forward Voltage	V _F	I _F = 350mA	-	12	12.5	V
Total Flux	Φ _v	I _F = 350mA	60	75	-	lm
Peak Wavelength	ρ	I _F = 350mA	-	635	-	nm
Dominant Wavelength	d	I _F = 350mA	620	-	630	nm
Spectral Line Half-width	Δλ	I _F = 350mA	-	20	-	nm
Reverse Current	I _R	V _R = 15V	-	-	50	μA
Thermal Resistance, Junction To Case	R _{J-C}	T _J = 25°C , I _F = 350mA(each die)	-	6	-	°C/W
Viewing Angle	2θ _{1/2}	I _F = 350mA	-	120	-	degree

● Typical electro-optical characteristics curves

Fig.1 RELATIVE INTENSITY VS. WAVELENGTH

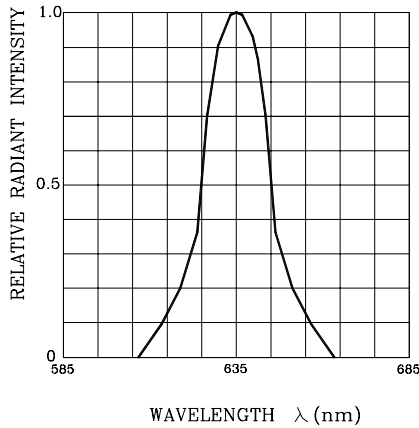

Fig.2 FORWARD CURRENT DERATING CURVE

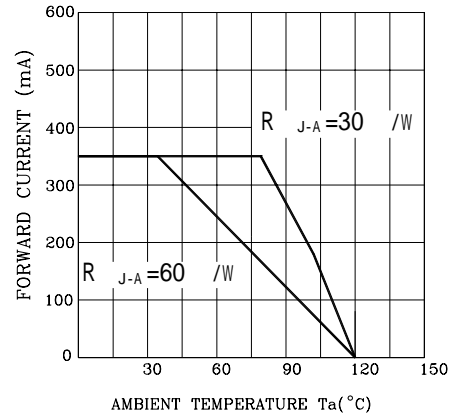

Fig.3 FORWARD CURRENT VS. FORWARD VOLTAGE

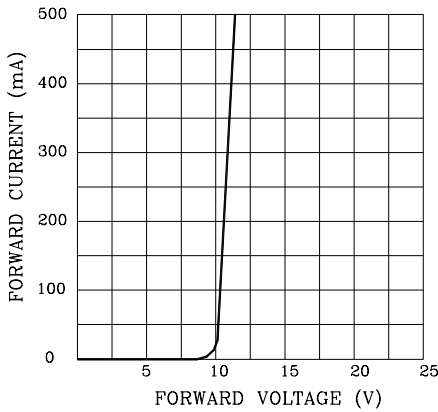

Fig.4 RELATIVE LUMINOUS INTENSITY VS. AMBIENT TEMPERATURE

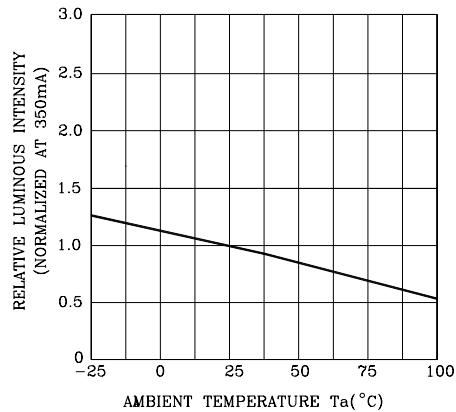

Fig.5 RELATIVE LUMINOUS INTENSITY VS. FORWARD CURRENT

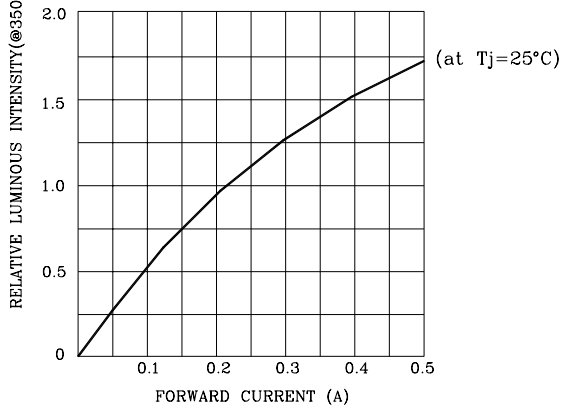
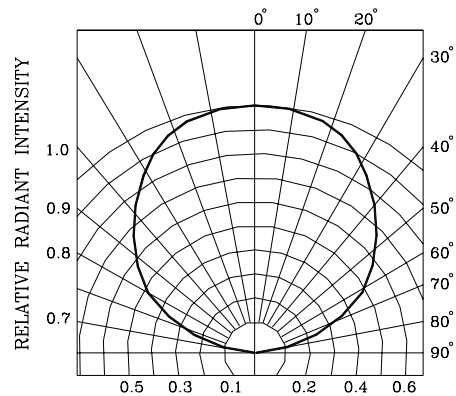
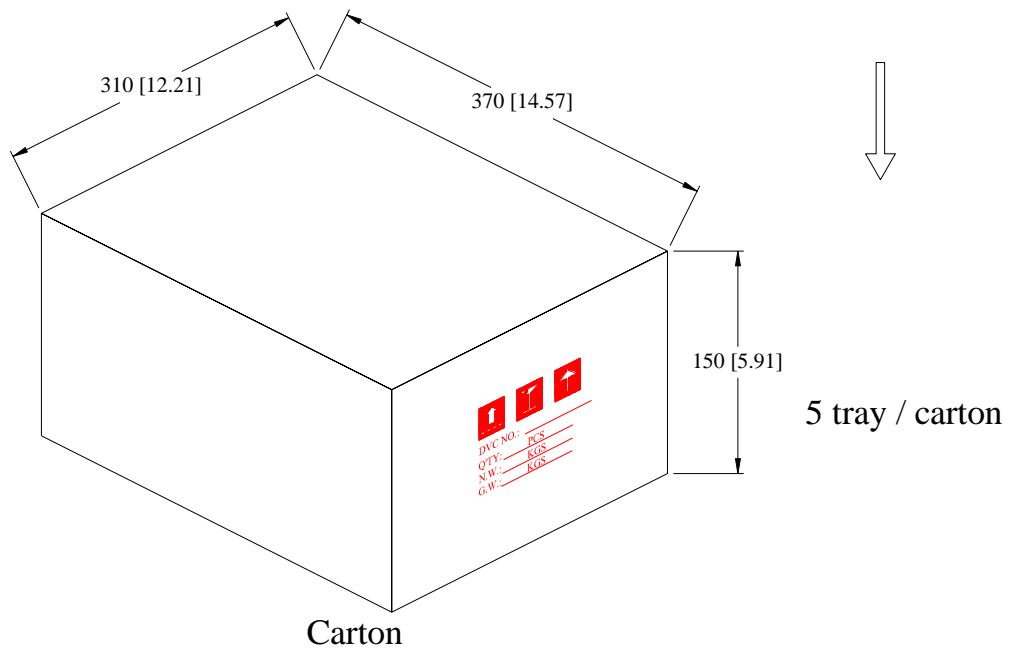
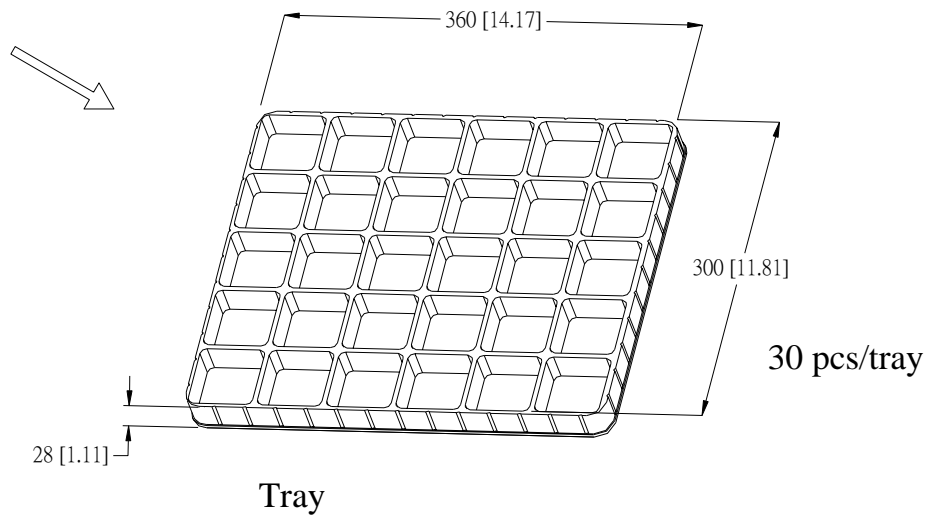
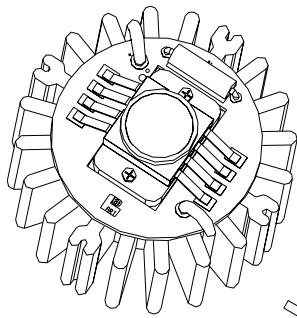

Fig.6 RADIATION DIAGRAM



● Package Method : (unit:mm)



NOTES : Tray : Tolerance is ± 5 mm unless otherwise noted.

Carton : Tolerance is ± 10 mm unless otherwise noted.